

VD-1600 Series Volume Control Dampers

Product Bulletin

VD-1600

Code No. LIT-1201735

Issued June 2018

Since 1885, Johnson Controls has provided the highest quality control dampers that fit your application and size requirements.

- VD-1620
galvanized triple-vee blade/galvanized frame
- VD-1630
galvanized airfoil blade/galvanized frame
- VD-1640
304 stainless steel triple-vee blades/stainless steel frames

Features and Benefits

- **3-Year Warranty on Materials and Workmanship**—Provides confidence of company standing behind product.
- **3-Working-Day Premium Shipping after Order Entry at No Additional Cost (VD-1620 and VD-1630 Models)**—Results in fast response for short lead time projects (subject to order size and factory capacity).
- **15-Working-Day Standard Shipping after Order Entry (VD-1640 Model)**—Results in fast response for short lead time projects.
- **1-Working-Day Fast Track Shipping after Order Entry with Cost Premium (VD-1620 and VD-1630 Models)**—Provides fast track (subject to order size and factory capacity).
- **5-Working-Day Fast Track Shipping (VD-1640 Model)**—Provides fast track (subject to order size and factory capacity and at a cost premium).
- **Self-Compensating Stainless Steel Side Seals**—Minimize leakage between the blades and the damper frame.

Applications

VD-1600 dampers are designed to meet different application and environmental requirements. These applications include but are not limited to:

- VD-1620 dampers with seals rated for Class II leakage resistance in applications requiring tight closure with less velocity, such as outdoor air

Figure 1: VD-1600 Volume Control Damper



- VD-1630 dampers with seals rated for Class IA leakage resistance in applications requiring very tight closure and high velocities
- VD-1640 dampers with seals rated for Class II leakage resistance in applications requiring 304 stainless steel construction

Dampers are tested at an Air Movement and Control Association (AMCA) Certified Laboratory using instrumentation and procedures in accordance with AMCA Standard No. 500, Test Methods for Louvers, Dampers, and Shutters.

Table 1: Leakage Resistance Classes

Pressure/ Class	Leakage, L/s/m ² (ft ³ /min/ft ²)			
	Required Rating - in. (kPa)		Extended Range (Optional) - in. (kPa)	
	1 (0.25)	4 (1.0)	8 (2.0)	12 (3.0)
1A	3 (15.2)	--	--	--
1	4 (20.3)	8 (40.6)	11 (55.9)	14 (71.1)
2	10 (50.8)	20 (102)	28 (142)	35 (178)
3	40 (203)	80 (406)	112 (569)	140 (711)

Construction

Table 2: Materials

Part	Materials
Frame	VD-1620/VD-1630: 5 in. x 1 in. x 16-gauge (127 mm x 25 mm x 1.6 mm) galvanized steel, hat channel shaped VD-1640: 5 in. x 1 in. x 16-gauge 304 stainless steel, U-channel shaped
Blades	VD-1620: 6 in. (152 mm) wide, triple vee-shaped, 16-gauge (1.6 mm) galvanized steel, approximately 6 in. (152 mm) on center VD-1630: Galvanized steel airfoil shaped double skin construction, 6 in. nominal construction, 8 in. maximum width VD-1640: 6 in. (152 mm) wide, triple vee-shaped, 16-gauge (1.6 mm) 304 stainless steel, approximately 6 in. (152 mm) on center
Blade Pin	1/2 in. (13 mm), plated steel hex
Linkage	Concealed in end channel of frame
Extension	1/2 in. (13 mm) diameter, 6 in. (152 mm) long pin included with all control dampers
Bearings	VD-1620: Synthetic VD-1630/VD-1640: Stainless steel
Side Seal	VD-1620/VD-1640: Self-compressing flexible metal or stainless steel VD-1630: Stainless steel; compression type
Blade Seal	VD-1620/VD-1640: PVC coated polyester fabric mechanically locked into blade edge, silicone optional VD-1630: Ruskiprene™ blade edge seal mechanically locked into blade edge, silicone optional

Figure 2: Damper Components

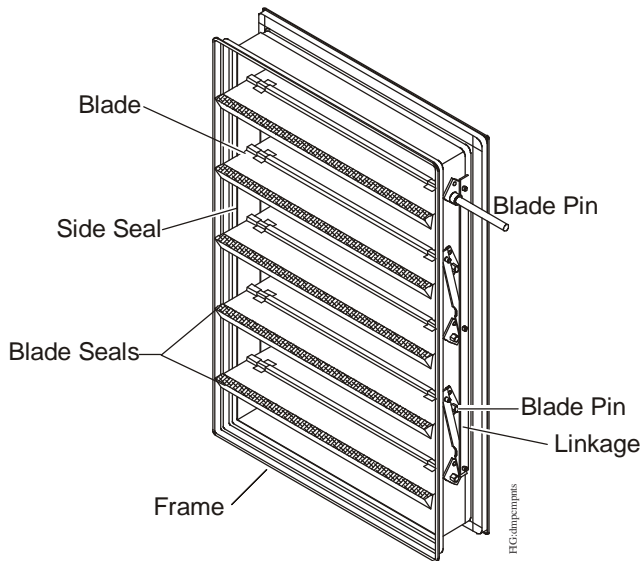

Each frame is made of 16-gauge steel, formed into channels, and welded with corner braces for additional strength.

Dimensions

Figure 3: Mounting Dimensions, in. (mm)

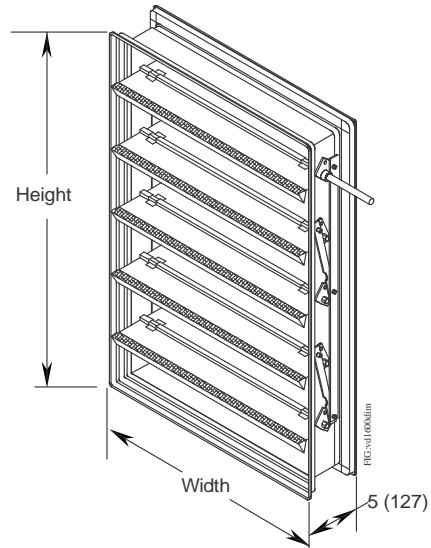
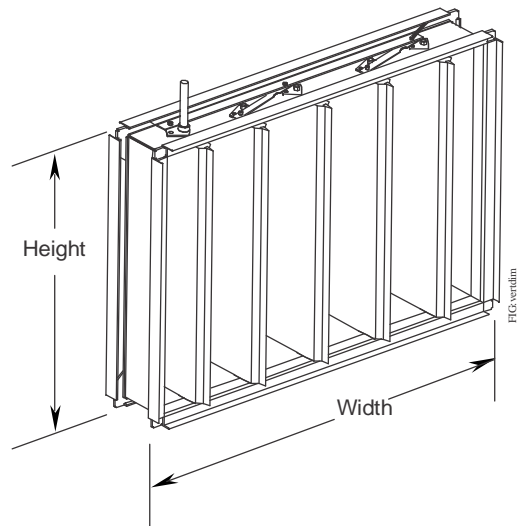

Figure 4: Mounting Dimensions Vertical Blades with Thrust Washers



All Johnson Controls height and width dimensions are from the outside edges of the frame. Actual damper size is 1/4-inch less than nominal.

Table 3: Single-Panel Size Limits

Dimension	Limits
Width	VD-1620: 5 to 48 in. VD-1630: 8 to 60 in. VD-1640: 6 to 48 in. VD-1630 with thrust washers: 6 to 48 in.
Height	VD-1620: 5 to 72 in. VD-1630: 6 to 72 in. VD-1640: 7 to 72 in. VD-1630 with thrust washers: 6 to 36 in.
Size Increment	1 in. increments

Airfoil blades are made from nominal 14-gauge galvanized steel in an airfoil shape for high performance. Blade and side seals are standard.

Figure 5: VD-1630 Airfoil Blade Profile

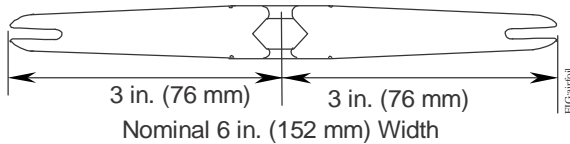

Triple-vee blades are made from one layer of 16-gauge formed sheet metal. Blade and side seals are standard.

The top and bottom blades may be up to 8 inches in width with up to 2-inch extensions on one side of each blade.

Figure 6: VD-1620/VD-1640 Triple-Vee Blade Profile

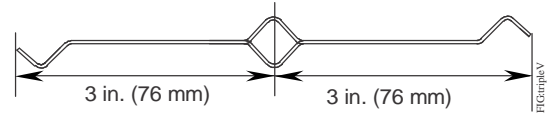

Note: All dimensions are nominal.

Selection Information

1. Configure your damper to the operation and performance required using Table 4.
2. Enter the width and height of the damper.

Note: Actual damper size is 1/4-inch less than nominal.

3. Enter the required options.

Table 4: Damper Selector¹

	Ordering Code Number	V				-	w	w	w	x	h	h	h			
Application	V = Volume Control															
Blade Operation	O = Opposed P = Parallel															
Blade/Frame	G = Galvanized Airfoil/Galvanized Steel (VD-1630) S = Triple-Vee 304 Stainless Steel (VD-1640) W = Triple-Vee Galvanized Steel (VD-1620)															
Bearing/Seal	S = Standard (Synthetic/PVC Coated Polyester) (VD-1620) S = Standard (Stainless Steel/PVC Coated Polyester) (VD-1640) S = Standard (Stainless Steel/Ruskiprene) (VD-1630) E = Extended (Stainless Steel/Silicone) (All Models) T = Thrust Bearing (Vertical Airfoil Blade) (VD-1630)															
Actuator²	A = M9208-AGC-3 or M9220-AGC-3 (24 V, Floating, Spring Return) B = M9208-GGC-3 or M9220-GGC-3 (24 V, Modulating, Spring Return) C = M9208-BAC-3 or M9220-BAC-3 (120 V, Two-Position, Spring Return) D = M9208-BGC-3 or M9220-BGC-3 (24 V, Two-Position, Spring Return) F = M9106-AGC-2 or M9116-AGC-2 (24 V Floating, Non-Spring Return) G = M9106-GGC-2 or M9116-HGC-2 (24 V Modulating, Non-Spring Return) N = No Actuator P = D-3062-3 or D-3153-2 (Pneumatic 8-13 lb Spring Range)															
Width	VD-1620 = 005 to 999 (Opposed and Parallel Blade) VD-1630 = 006 to 999 (Vertical Blade), 008 to 999 (Opposed and Parallel Blade) VD-1640 = 005 to 192 (Opposed and Parallel Blade)															
Height	VD-1620 = 005 to 999 (Opposed and Parallel Blade) VD-1630 = 006 to 999 (Parallel Blade), 008 to 999 (Vertical Blade), 010 to 999 (Opposed Blade) VD-1640 = 005 to 228 (Opposed and Parallel Blade)															
Options (limit two)	See <i>Factory Options</i> for descriptions and combinations.															

1. Not all combinations are available; in addition to checking this damper selector table, see *Factory Options* for valid combinations.
2. Actuators may restrict maximum sizes; check selector tool for valid maximum sizes. By default, actuators come externally mounted (outside air stream). Use option Q for internally mounted actuators.

Factory Options

- E** Exact whole inch size, no undercut
- F** 1.5 in. L flange air entering side (cannot be used with option G or H)
- G** 1.5 in. L flange air leaving side (cannot be used with option F or H)
- H** Double flange (cannot be used with option F or G)
- I** Indicator switch
- J** Field installed jackshaft on single panel (multiple section units broken down and shipped in sections)
- M** Factory installed jackshaft on single panel units
- Q** Internal mount actuator (actuator mounted in air stream, minimum electric actuator 14 x 21 in., minimum pneumatic actuator 18 x 24 in.)
- V** Transition (round/oval) (VD-1620 and VD-1630)

Note: When the transition option is selected, the damper is 2 inches larger than the round or oval duct for the transition. For example, the VOGSN-014x014V has a 16 in. x 16 in. damper used with a 14 in. round duct. The VOGSN-014x024V has a 16 in. x 26 in. damper used with a 14 in. x 24 in. oval duct.

Multiple Section Stacking Details

Multiple section dampers are shipped assembled from the factory and include jackshafts.

Figure 7: Multiple Section Stacking Options

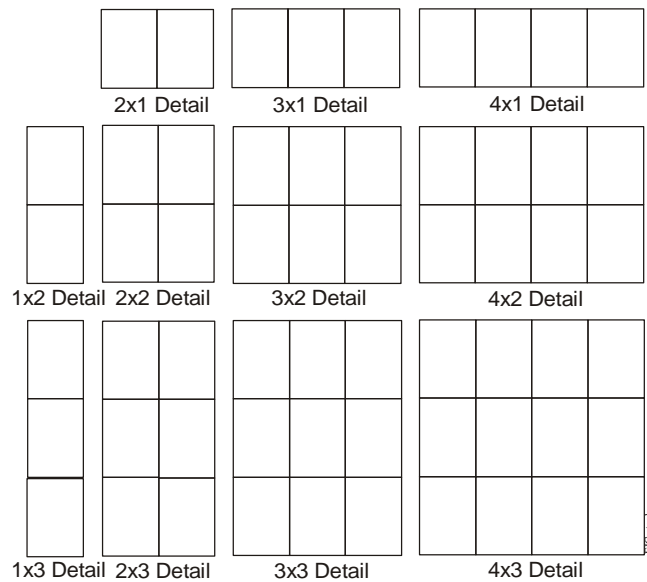

Maintenance

Johnson Controls® VD-1600 dampers have no components that require routine scheduled maintenance.

During normal duct maintenance, damper blades should be wiped clean if necessary and opened and closed to verify complete rotation and sealing.

Table 5: Repair Parts

Code Number	Description
DMPR-RC058	PVC Coated Fiberglass Seal for VD-1620; 10 ft long
DMPR-RC059	Silicone Seal for Parallel and Opposed Bladed VD-1620; 10 ft long
DMPR-RC060	Santoprene® Seal for Parallel and Opposed Bladed VD-1630; 10 ft long
DMPR-RC061	Silicone Seal for Parallel and Opposed Bladed VD-1630; 10 ft long
DMPR-RC062	Santoprene Blade Stop Seal for VD-1630; 10 ft long
DMPR-RC069	Silicone Blade Stop Seal for VD-1630; 10 ft long

Return Policy

All Johnson Controls Dampers are built to order and cannot be returned due to customer ordering errors. All dampers are backed by a 3-year warranty that covers defects in materials or workmanship. Refer to terms and conditions of sale for specifics.

Technical Specifications

VD-1600 Volume Control Dampers¹

Leakage	VD-1620/VD-1640		5.4 cfm/sq ft maximum at 1 in. static pressure for 48 in. wide damper 10.7 cfm/sq ft maximum at 4 in. static pressure for 48 in. wide damper			
	VD-1630		3 cfm/sq ft maximum at 1 in. static pressure for 48 in. x 48 in. wide damper 8 cfm/sq ft maximum at 4 in. static pressure for 48 in. x 48 in. wide damper			
Operating Torque	VD-1640		0.5 in. static pressure, 100 fpm fully open approach velocity 1 in. static pressure, 1,000 fpm fully open approach velocity 10 in. static pressure, 2,500 fpm fully open approach velocity		5 lb-in/sq ft 5 lb-in/sq ft 7 lb-in/sq ft	
	VD-1620/VD-1630		0.5 in. static pressure, 100 fpm fully open approach velocity 1 in. static pressure, 1,000 fpm fully open approach velocity		3.25 lb-in/sq ft 4.25 lb-in/sq ft	
Pressure Drop (inches WG) - Fully Open	Size (in.)		Approach Velocity (fpm)			
			1,000	2,000	3,000	4,000
	VD-1620	24 x 24	0.045	--	0.40	--
	VD-1630	24 x 24	0.025	0.10	0.25	--
	VD-1640	24 x 24	0.045	--	0.40	--
Velocity and Pressure Limits			Width (in.)			
			12	24	36	48
	VD-1630		6,000 fpm at 11 in. static	--	3,000 fpm at 7 in. static	1,500 fpm at 5.0 in. static
	VD-1620/VD-1640		1,500 fpm at 5 in. static	1,500 fpm at 4 in. static	1,500 fpm at 4 in. static	1,500 fpm at 2.5 in. static
Temperature Rating	VD-1620	Standard and Extended Operating Conditions	-25 to 180°F (-32 to 83°C)			
	VD-1630	Extended Operating Condition	-72 to 275°F (-60 to 135°C)			
		Standard Operating Condition	-40 to 200°F (-40 to 93°C)			
	VD-1640	Standard and Extended Operating Conditions	-25 to 180°F (-32 to 83°C)			
	Actuator		-4 to 122°F (-20 to 50°C)			
Approximate Weight	VD-1620		5 lb/sq ft (2.27 kg/sq ft)			
	VD-1630		7 lb/sq ft (3.2 kg/sq ft)			
	VD-1640		7 lb/sq ft (3.2 kg/sq ft)			
	Actuator		2.9 pounds (1.6 kg) per actuator			

1. All performance data is determined using instrumentation and procedures at an AMCA Certified Laboratory in accordance with AMCA Standard No. 500, Test Methods for Louvers, Dampers, and Shutters.

The performance specifications are nominal and conform to acceptable industry standards. For application at conditions beyond these specifications, consult the local Johnson Controls office. Johnson Controls shall not be liable for damages resulting from misapplication or misuse of its products. Refer to the M9208-xxx-x Series Electric Spring Return Actuators Product Bulletin (LIT-12011480), M9220-xxx-3 Electric Spring Return Actuators Product Bulletin (LIT-12011057), and M9108, M9116, M9124, and M9132 Series Electric Non-spring Return Actuators Product Bulletin (LIT-2681058) for necessary information on operating and performance specifications for the actuator.



Building Technologies & Solutions
507 E. Michigan Street, Milwaukee, WI 53202

Metasys® and Johnson Controls® are registered trademarks of Johnson Controls.
All other marks herein are the marks of their respective owners. © 2018 Johnson Controls.